

S101

Dust Detector for Filter Monitoring

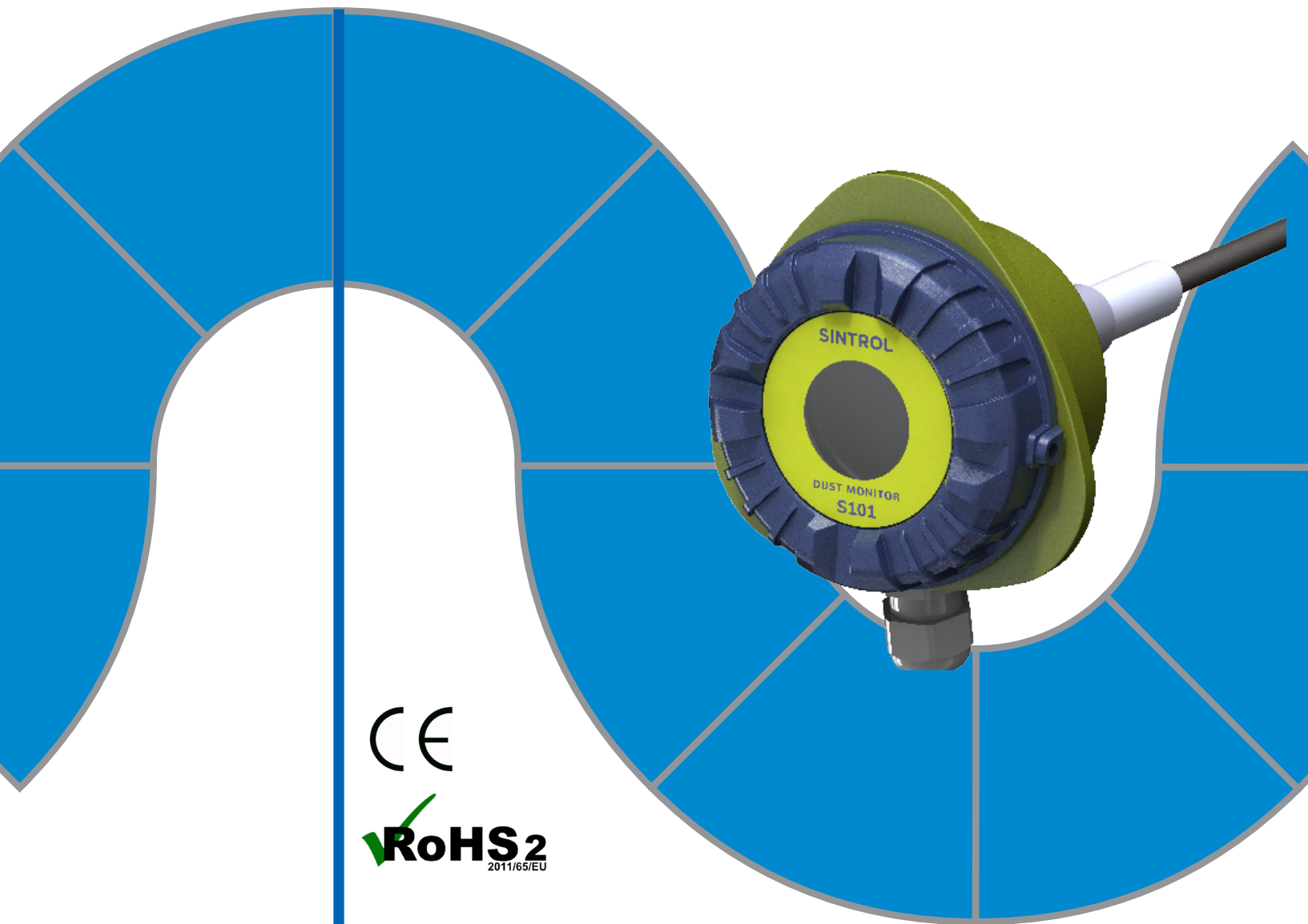

- **High performance dust detector**
 - Detects any particulates in the air-flow
 - Very fast response to any dust leaks
- **Rugged, IP66 rated design for harsh industrial conditions**
- **User friendly, straightforward interface**
 - Visible Green, Yellow and Red LED to indicate dust levels
- **Easy start-up and commissioning**
- **Two independent solid-state relay outputs**

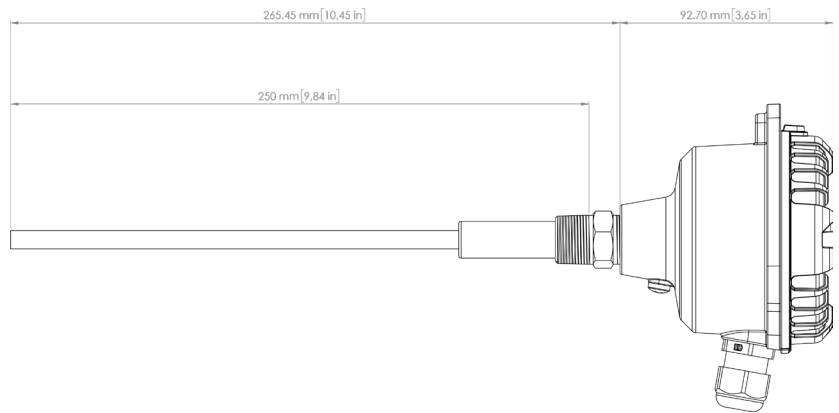
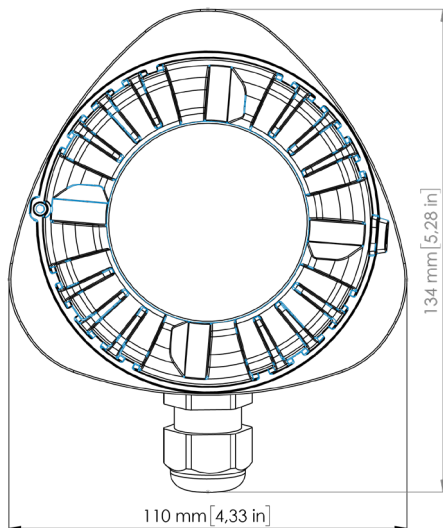

SIN101/120521

Product Name		S101
Measured objects	Solid particles in gas flow	
Measurement principle	Inductive Electrification	
Measurement range	Detection limit 0,01 mg/m ³ Max. range up to several g/m ³ depending on operating conditions	
Ingress protection	IP66	
Power supply	24 V DC ±10 %	
Power consumption	1 W	
Output signals	2 × Independent solid-state relays, max. 30 V DC / 200 mA	
Communication interface	RS-485	
Communication protocol	<ul style="list-style-type: none"> • Modbus RTU • Sintrol network 	
Physical characteristics		
Enclosure	Aluminium	
Probe length	250 mm. (9,84 in), can be shortened by the user	
Wetted parts	<ul style="list-style-type: none"> • Probe: Stainless steel (316L) • Insulation: Polyether ether ketone (PEEK) 	
Weight	0,7 kg (1.54 lb)	
Ambient conditions		
Temperature	-40 ... 60 °C (-40 ... 140 °F)	
Humidity	Max. 90 % relative humidity (non-condensing)	
Process conditions		
Temperature	Max. 250 °C (482 °F)	
Pressure	Max. 200 kPa (29 psi)	
Flow speed	Min. 3 m/s (9.84 ft/s)	